



Alüminyum Kompozit Panel Renk Kartelası
Aluminium Composite Panel Color Chart

Alüminyum Kompozit Panel Renk Kartelası
Aluminium Composite Panel Color Chart





Panel Renk Kartelası
Panel Color Chart

Renk Kartelası
Color Chart
Alüminyum Kompozit Panel Renk Kartelası
Aluminium Composite Panel Color Chart

ALANI
YUZEY KONTROL

SOGUTMA KABINI ALANI

Alüminyum Kompozit Panel
Aluminium Composite Panel

ALÜMİNYUM KOMPOZİT PANEL

1990'dan bu yana sektördeki birçok ilke imza atan **ASAŞ**, 2006 yılında Türkiye'deki ilk alüminyum kompozit panel üretim tesisini kurarak yeniliklerin Türkiye'ye kazandırılmasında öncü bir rol üstlenmenin gururunu taşımaktadır. Sektörün **hem ilk yerli hem de lider ürünü** olan kompozit panel ürünlerimiz farklı desen ve renk seçeneklerinin yanı sıra dünya standartlarında yüksek kalitesi, dayanıklılığı, kolay işlenebilmesi, yüzey düzgünlüğü, hafifliği ve geniş ürün yelpazesıyla en çok tercih edilen inşaat, dekorasyon, mobilya ve reklam ürünleri arasındadır. Kompozit panel üretim tesisi, bünyesinde bulunan 4 hat ile yılda 7.500.000m² alüminyum kompozit panel üretim kapasitesi ile hizmet vermektedir. Alüminyum kompozit panellerin üretiminde kullanılan boyalı alüminyum levhalar, 2014 yılında kurulan son teknoloji ile donatılmış **ASAŞ** Yassı Mamuller Üretim Tesisinde müşterilerimizin ihtiyaç ve beklentilerine uygun olarak üretilmektedir.

İleri teknolojinin kullanıldığı tesiste; farklı ölçü ve geniş renk yelpazesi ile konvansiyonel düşük yoğunluklu polietilen dolgulu alüminyum kompozit panellerin yanı sıra, alüminyum hidroksit dolgulu ve yangına dayanıklı özel alüminyum kompozit paneller üretilmektedir.

Tüm ürünler, ileri teknoloji ile donatılmış laboratuvarlarda kalite mühendislerince test edilmekte, uluslararası kalite standartlarına uygun olarak müşterilere sunulmaktadır.

ALUMINIUM COMPOSITE PANEL

ASAŞ which has been a trendsetter in the industry many times since 1990, is also proud to be a pioneer by founding the first composite panel production facility in Turkey in 2006. Our composite panel products are the **first native and leader ones** in the industry thanks to its various design & color options, highest quality standards, durability, easy processability, smooth finishing, lightness and wide range of products. They are amongst the most preferred products by construction, decoration, furniture and advertisement industries. The composite panel production facility operates with 4 lines and has the capacity of 7.500.000m² aluminium composite panel production. Painted aluminium sheets used in the production of aluminium composite panel are produced according to the needs and expectations of our customers in our **ASAŞ** Flat Rolled Products Production Facility which is founded in 2014.

Thanks to our high technology facility, both aluminium composite panels with various dimensions and colors which are filled with low dense polyethylene and non-flammable custom composite panels which are filled with aluminium hydroxide can be produced.

All products are tested in the labs with the most modern equipments by quality engineers and served to our customers only after meeting the international quality standards.



ASAŞ

Kurulduğu 1990 yılından beri istikrarlı büyüme trendi ile 2016 yılında Türkiye’de ISO 500’de 79. Sıraya yükselen, aynı zamanda Avrupa’daki lider üreticilerden biri olan **ASAŞ**;

- 80’i aşkın ülkeye ihracat yapmakta
- Grup bünyesinde 2200’den fazla çalışanı ile
- Sakarya’da 300.000m² alanı kapalı olmak üzere; toplamda 640.000m² bir alanda, en modern teknoloji ile donatılmış tesislerinde üretim faaliyetlerini yürütmektedir.

ASAŞ çok sayıda başarılı iş birimlerini ve üretim tesislerini tek çatı altında bulundurmaktadır:

- Alüminyum Ekstrüzyon (eloksallı, elektrostatik toz boyalı, mekanik işlemlerli profiller)
- Alüminyum Yassı Mamuller (levha, rulo, folyo, boyalı rulo)
- Alüminyum Mimari Sistemler
- Alüminyum Kompozit Panel (giydirmeye cephe, cephe kaplaması ve reklam uygulamaları)
- PVC Kapı ve Pencere Sistemleri
- Panjur ve Kepenk Sistemleri
- Alüminyum Tasarım Ürünleri (bayrak direkleri, aydınlatma direkleri, raf sistemleri)
- ASAŞSANAT (sanatçılar, akademisyenler ve öğrenciler için yaratıcı bir platform)

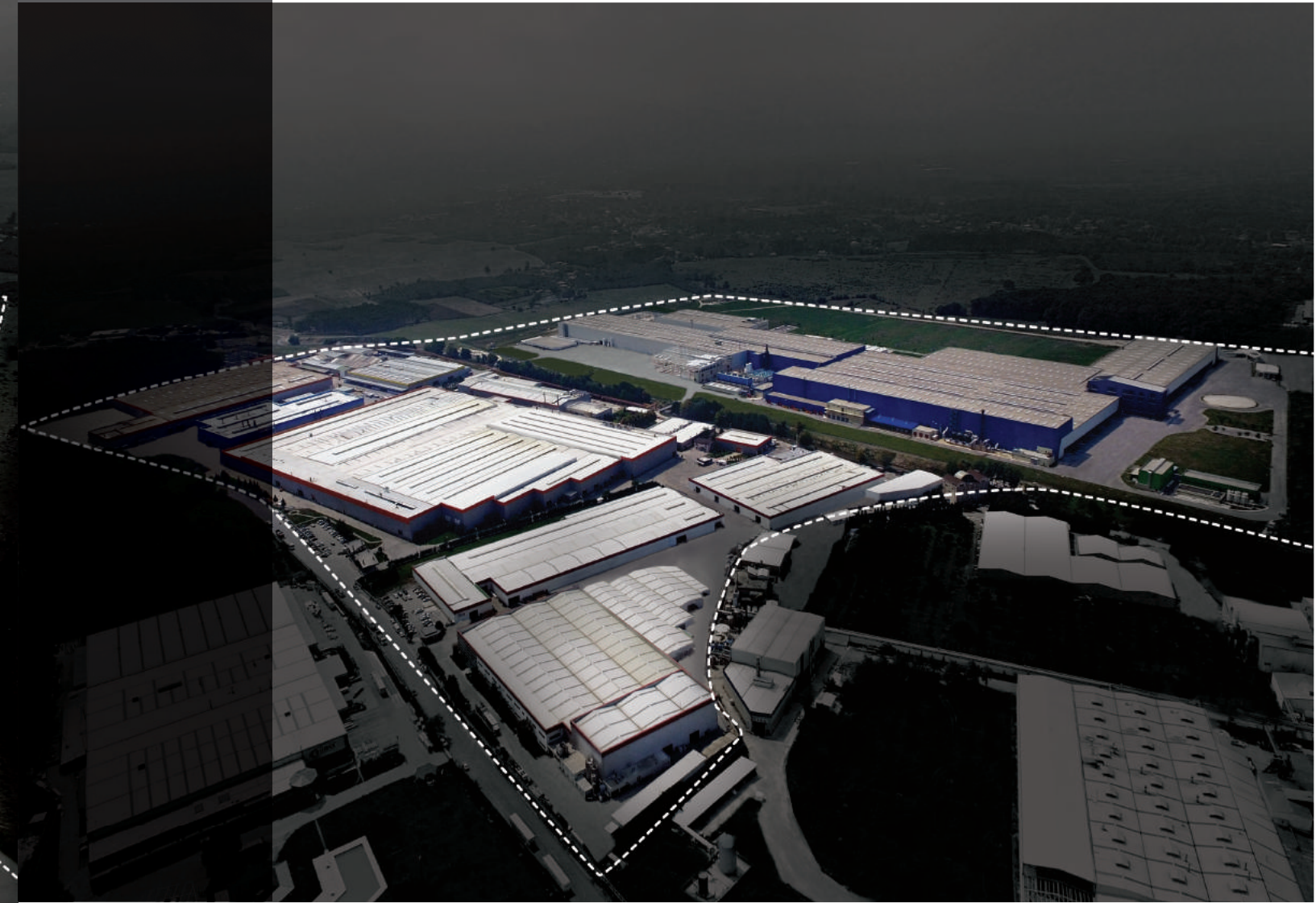

ASAŞ

Since its founding in 1990, **ASAŞ** has grown steadily and it rose in ranking to 79 on Turkey's Top 500 Industrial Companies List in 2016 and it became one of Europe's leading manufacturing companies. **ASAŞ** is currently;

- Exporting to over 80 countries
- Employing over 2200 highly skilled people across the group
- Operates in a 640.000m² site in Sakarya / Turkey, of which 300.000m² is closed and equipped with the latest technology.

ASAŞ currently includes a number of highly successful business units and production facilities under the same roof:

- Aluminium Extrusion (anodized, powder coated, machined profiles)
- Aluminium Flat Rolled Products (sheet, coil, foil, coated coil)
- Aluminum Architectural Systems
- Aluminium Composite Panel (for facade, cladding and signboards)
- PVC Window and Door Systems
- Roller Shutter and Steel Shutter Systems
- Aluminium Design Products (flag poles, lighting poles, shelf systems)
- ASAŞART (creative platform for artists, academicians and students)

NATURALBOND B2

50+50 | PVDF

Alüminyum Üst Levha Kalınlığı / Aluminium Top Sheet Thickness: 0,5mm
Alüminyum Alt Levha Kalınlığı / Aluminium Bottom Sheet Thickness: 0,5mm
PVDF Boyalı / PVDF Painted
20 yıl Garanti* / 20 Years of Warranty*

(*) Asař tarafından önerilen alüminyum alt konstrüksiyon ve montaj detaylarının kullanılması kořulu ile Naturalbond kompozit panelleri 20 yıl garantilidir.

(*) Naturalbond composite panels have 20 years of warranty as long as the aluminium bottom construction and the assembling directions are practised as advised by ASAŞ.

Kompozit Panel Katmanları / Composite Panel Layers

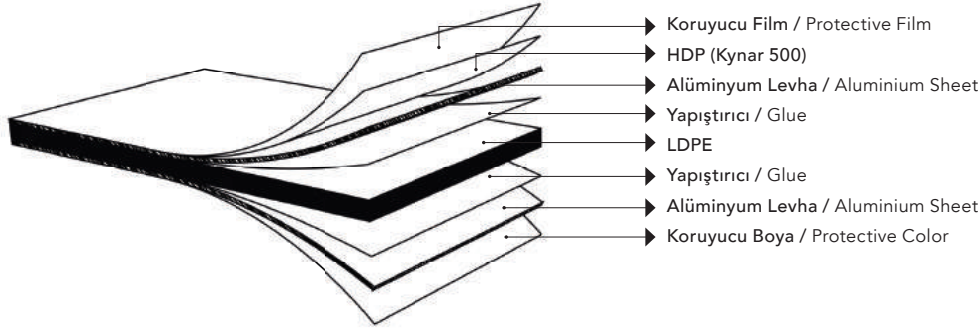

Teknik Bilgiler / Technical Specifications

Standart 4mm kalınlığındaki Naturalbond 50+50 kompozit panel için /
For standard 4mm thick Naturalbond 50+50 composite panel:

Levha Alařım - Kondisyon / Sheet Alloy - Condition	: EN AW-3105 / H46
Alüminyum Levha Kalınlık / Aluminium Sheet Thickness	: Üst Levha / Top Sheet: 0,50mm (±0,02mm) Alt Levha / Bottom Sheet: 0,50mm (±0,02mm)
Kompozit Panel Toplam Kalınlık / Composite Panel Total Thickness	: 4mm (±0,2mm)
Dolgu / Filling	: Yangın Tepki Sınıfına Göre Deęişken - Kalınlık: 3mm Depending On The Flammability Class - Thickness: 3mm
Üst Levha Kaplama / Top Sheet Coating	: Kynar 500 Bazlı PVDF Boya (20+5 mikron) Kynar 500 Based PVDF Paint (20+5 micron)
Alt Levha / Bottom Sheet	: Polyester Bazlı Koruyucu Boya / Polyester Based Protective Paint

Yanmazlık Sınıfı / Non-flammability Class

Ürün Adı Product Name	Dolgu Malzemesi Filling Material	DIN 4102 Yangın Tepki Sınıfı Flammability Class	TS EN 13501-1 Yangın Tepki Sınıfı Flammability Class
Naturalbond 50+50	LDPE	B2	D-s1,d0
Naturalbond 50+50	LDPE+AL(OH)	B1 (FR)	B-s1,d1
Naturalbond 50+50	Mineral Dolgu	A2	A2-s1,d0

Ürün Çeşitleri / Types of Products

Kompozit Panel Kalınlığı / Composite Panel Thickness	: 3mm - 6mm (EN 485-4)
Kompozit Panel Geniřliđi / Composite Panel Width	: 1250mm, 1500mm
Maksimum Üretim Uzunluđu / Maximum Production Length	: 6000mm
Standart Üretim Ölçüleri / Standard Production Measurements	: 1250mm x 3200mm : 1500mm x 3200mm

Üretim Toleransları / Tolerances on Production

Kompozit Panel Kalınlığı / Composite Panel Thickness	: ±0,2mm
Kompozit Panel Geniřliđi / Composite Panel Width	: -0mm / +2,0mm
Kompozit Panel Uzunluđu / Composite Panel Length	: -0mm / +4,0mm
Diyagonal Fark / Diagonal Difference	: max. 3,0mm
Dođrusallık (Geniřlik ve Uzunluk) / Linearity (Width and Length)	: ±0,2mm
Eđiklik / Inclination	: max 5mm (Panel uzunluđu / Panel length < 1500mm) max 7mm (Panel uzunluđu / Panel length: 1500mm - 3000mm)

Panel Deformasyon Risk Tablosu / Risk Table for Panel Deformation

Rüzgar Yüğü Wind Load (Kpa)	Panel Ebatları / Panel Dimensions (mm)										
	En Width	Boy Length	600	900	1200	1500	1800	2100	2400	2700	3000
51	900		11%	19%	24%	26%	27%	27%	28%	28%	28%
	1200		21%	41%	51%	57%	61%	63%	66%	67%	69%
	1500		38%	69%	84%	92%	97%	100%	103%	105%	107%
102	900		22%	36%	43%	47%	49%	51%	52%	52%	53%
	1200		44%	46%	83%	89%	95%	98%	102%	104%	106%
	1500		79%	115%	129%	135%	140%	144%	147%	150%	152%
151	900		41%	57%	74%	88%	91%	92%	94%	96%	97%
	1200		62%	74%	96%	107%	109%	111%	111%	111%	112%
	1500		95%	105%	120%	129%	130%	131%	135%	137%	137%
202	900		44%	63%	71%	77%	82%	85%	88%	89%	90%
	1200		87%	114%	126%	132%	138%	142%	147%	149%	149%
	1500		145%	174%	185%	190%	194%	197%	201%	203%	205%
252	900		55%	96%	118%	128%	134%	136%	138%	138%	139%
	1200		106%	204%	256%	284%	304%	317%	329%	336%	343%
	1500		189%	347%	422%	458%	483%	500%	517%	527%	535%

Deformasyon / Deformation
% Risk / % of Risk

Yeşil: İdeal kullanılabilir / Green: Can be used as ideal

Sarı: Tekrar kontrol edilmeli (statik hesap yapılmalı) / Yellow: Should be recontrolled. (Static calculation is needed)

Siyah: Takviye olmadan kullanılamaz / Black: Can't be used without reinforcement

NATURALBOND B2

FR
40+40 | PVDF

Alüminyum Üst Levha Kalınlığı / Aluminium Top Sheet Thickness: 0,4mm
Alüminyum Alt Levha Kalınlığı / Aluminium Bottom Sheet Thickness: 0,4mm
PVDF Boyalı / PVDF Painted
20 yıl Garanti* / 20 Years of Warranty*

(*) Asağ tarafından önerilen alüminyum alt konstrüksiyon ve montaj detaylarının kullanılması koşulu ile Naturalbond kompozit panelleri 20 yıl garantilidir.

(*) Naturalbond composite panels have 20 years of warranty as long as the aluminium bottom construction and the assembling directions are practised as advised by ASAŞ.

Kompozit Panel Katmanları / Composite Panel Layers

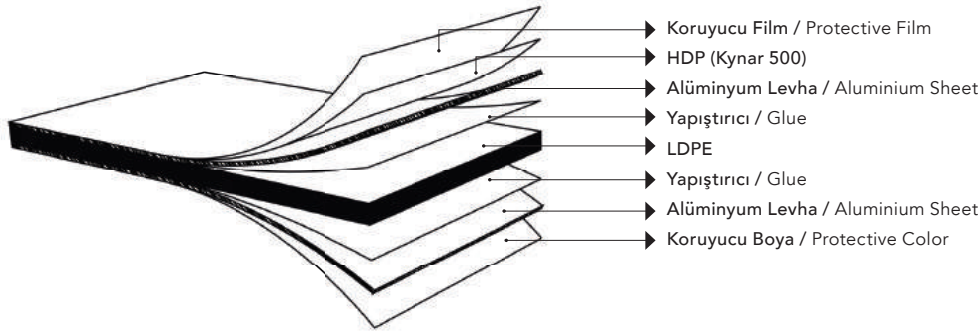

Teknik Bilgiler / Technical Specifications

Standart 4mm kalınlığındaki Naturalbond 40+40 kompozit panel için /

For standard 4mm thick Naturalbond 40+40 composite panel:

Levha Alaşım - Kondisyon / Sheet Alloy - Condition : EN AW-3105 / H46

Alüminyum Levha Kalınlık / Aluminium Sheet Thickness : Üst Levha / Top Sheet: 0,40mm (±0,02mm)

Alt Levha / Bottom Sheet: 0,40mm (±0,02mm)

Kompozit Panel Toplam Kalınlık / Composite Panel Total Thickness : 4mm (±0,2mm)

Dolgu / Filling

: Yangın Tepki Sınıfına Göre Değişken - Kalınlık: 3,2mm

Depending On The Flammability Class - Thickness: 3,2mm

Üst Levha Kaplama / Top Sheet Coating

: Kynar 500 Bazlı PVDF Boya (20+5 mikron)

Kynar 500 Based PVDF Paint (20+5 micron)

Alt Levha / Bottom Sheet

: Polyester Bazlı Koruyucu Boya / Polyester Based Protective Paint

Yanmazlık Sınıfı / Non-flammability Class

Ürün Adı Product Name	Dolgu Malzemesi Filling Material	DIN 4102 Yangın Tepki Sınıfı Flammability Class	TS EN 13501-1 Yangın Tepki Sınıfı Flammability Class
Naturalbond 40+40	LDPE	B2	D-s1,d0
Naturalbond 40+40	LDPE+AL(OH)	B1 (FR)	B-s1,d1

Ürün Çeşitleri / Types of Products

Kompozit Panel Kalınlığı / Composite Panel Thickness	: 3mm - 6mm (EN 485-4)
Kompozit Panel Geniřliđi / Composite Panel Width	: 1250mm, 1500mm
Maksimum Üretim Uzunluđu / Maximum Production Length	: 6000mm
Standart Üretim Ölçüleri / Standard Production Measurements	: 1250mm x 3200mm : 1500mm x 3200mm

Üretim toleransları / Tolerances on Production

Kompozit Panel Kalınlığı / Composite Panel Thickness	: ±0,2mm
Kompozit Panel Geniřliđi / Composite Panel Width	: -0mm / +2,0mm
Kompozit Panel Uzunluđu / Composite Panel Length	: -0mm / +4,0mm
Diyagonal Fark / Diagonal Difference	: max. 3,0mm
Dođrusallık (Geniřlik ve Uzunluk) / Linearity (Width and Length)	: ±0,2mm
Eđiklik / Inclination	: max 5mm (Panel uzunluđu / Panel length < 1500mm) max 7mm (Panel uzunluđu / Panel length: 1500mm - 3000mm)

Panel Deformasyon Risk Tablosu / Risk Table for Panel Deformation

Rüzgar Yüğü Wind Load (Kpa)	Panel Ebatları / Panel Dimensions (mm)										
	En Width	Boy Length	600	900	1200	1500	1800	2100	2400	2700	3000
51	900		14%	22%	26%	28%	29%	30%	31%	31%	32%
	1200		28%	42%	47%	50%	53%	55%	56%	57%	58%
	1500		49%	66%	71%	74%	76%	77%	79%	80%	81%
102	900		28%	44%	51%	56%	59%	60%	62%	63%	63%
	1200		56%	84%	95%	101%	106%	109%	113%	115%	117%
	1500		98%	131%	143%	148%	152%	155%	158%	160%	162%
151	900		42%	60%	68%	73%	78%	80%	83%	83%	85%
	1200		85%	83%	109%	119%	125%	131%	134%	138%	142%
	1500		136%	165%	174%	186%	193%	202%	208%	211%	214%
202	900		55%	73%	82%	88%	93%	96%	99%	100%	101%
	1200		105%	129%	139%	145%	150%	153%	157%	159%	162%
	1500		167%	191%	199%	203%	206%	209%	211%	213%	215%
252	900		84%	120%	137%	147%	156%	161%	165%	167%	169%
	1200		169%	165%	218%	239%	250%	261%	268%	276%	284%
	1500		273%	329%	348%	371%	386%	403%	415%	423%	428%

Deformasyon / Deformation
% Risk / % of Risk

Yeřil: İdeal kullanılabilir / Green: Can be used as ideal

Sarı: Tekrar kontrol edilmeli (statik hesap yapılmalı) / Yellow: Should be recontrolled. (Static calculation is needed)

Siyah: Takviye olmadan kullanılamaz / Black: Can't be used without reinforcement

RENKLER / COLORS



DÜZ RENKLER / SOLID COLORS



NB 901
Beyaz - Pure White

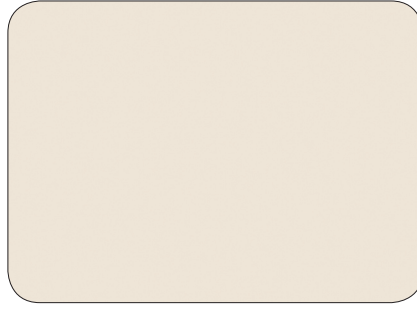

NB 912
Krem - Cream White



NB 104
İnci Beyaz - Pearl White

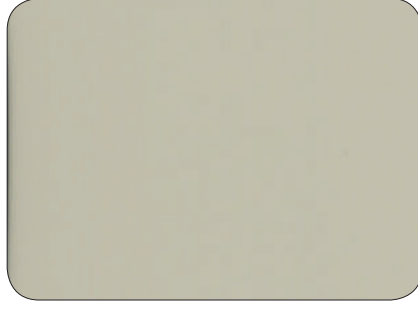

NB 604
Yeşil Gri - Grey Green

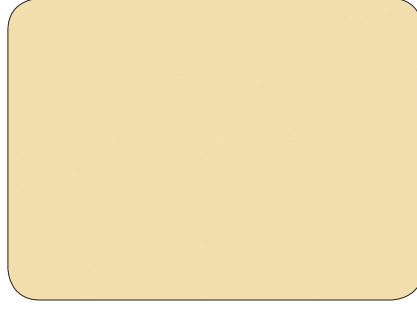

NB 101
Fildişi Bej - Ivory Sand

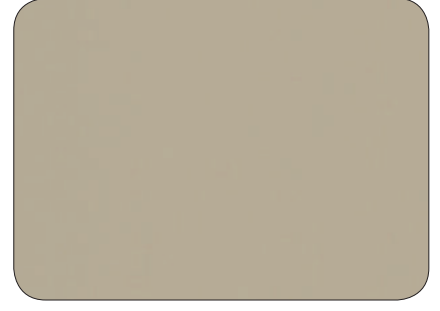

NB 107
Gri Bej - Grey Beige

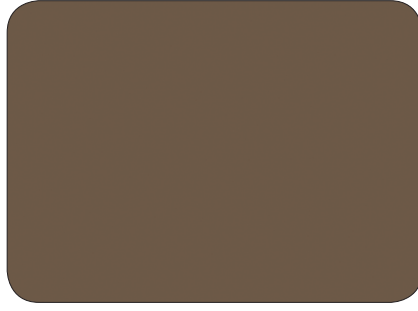

NB 381
Açık Kahverengi - Pale Brown

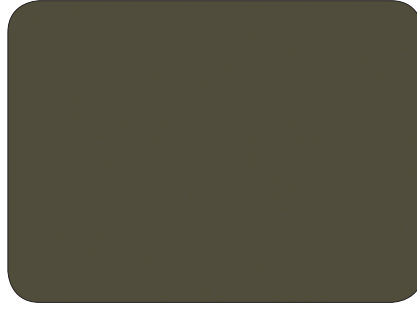

NB 382
Toprak Kahve - Soil Brown



NB 505
Lacivert - Gentian Blue



NB 503
Deniz Mavisi - Ultramarine Blue



NB 504
Çelik Mavi - Steel Blue



NB 701
Platin Gri - Platinum Grey



NB 703
Grafit Gri - Graphite Grey



NB 951
Siyah - Graphite Black



NB 304
Şeker Pembe - Erika Violet



RENKLER / COLORS

RENKLER
COLORS

DÜZ RENKLER / SOLID COLORS

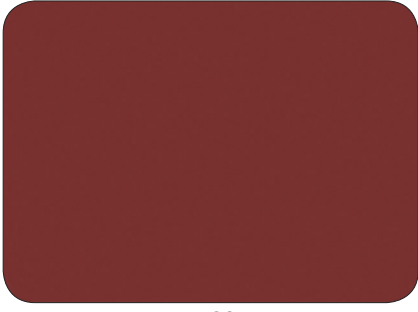

NB 301
Bordo - Red Brown

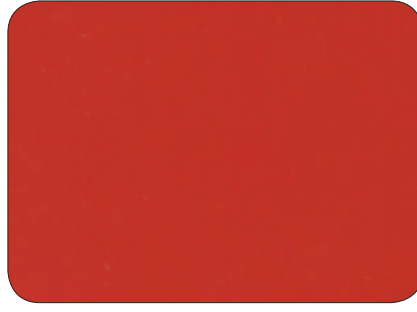

NB 302
Kırmızı - Traffic Red

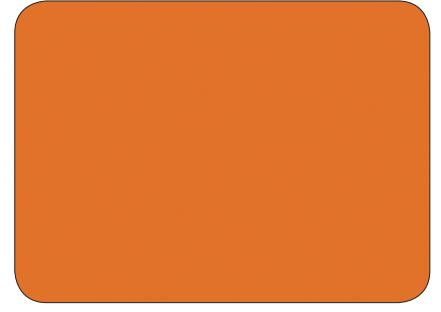

NB 202
Turuncu - Orange



NB 102
Sarı - Rape Yellow



NB 603
Yosun Yeşili - Moss Green

METALİK RENKLER / METALLIC COLORS

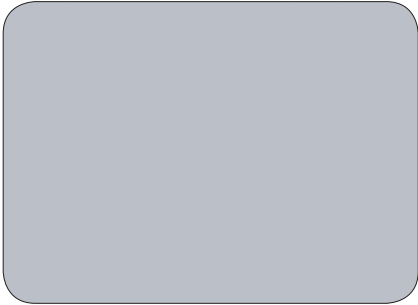

NB 090
Metalik Gümüş - Metallic Silver

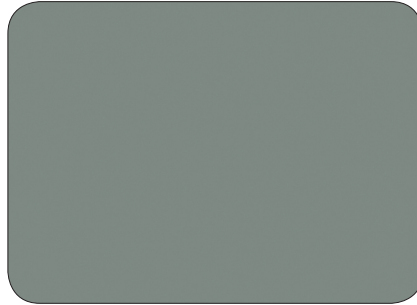

NB 080
Açık Bronz - Lys Bronze

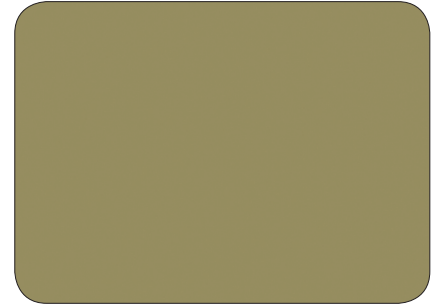

NB 011
Altın Sarısı - Pearl Gold



NB 081
Bakır - Copper



NB 050
Metalik Açık Mavi - Azul Blue



NB 702
Metalik Koyu Gri - Metallic Dark Grey



RENKLER / COLORS

RENKLER
COLORS

AHŞAP RENKLER / WOOD COLORS

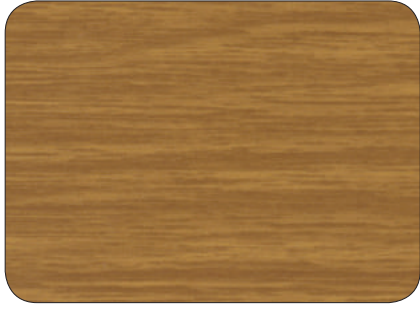

NB 874
Koyu Altın Meşe - Kiefer Line Wood

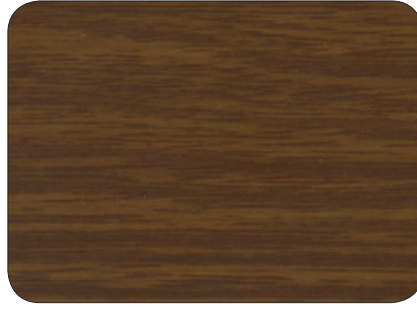

NB 857
Kalın Altın Meşe - Golden Oak Line Wood

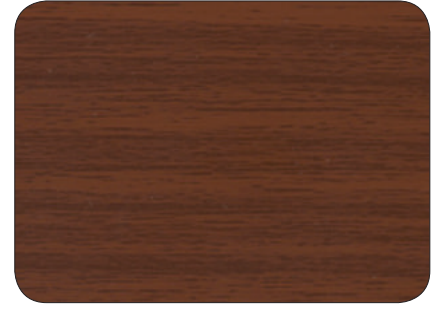

NB 872
Doğal Meşe - Natural Oak



NB 870
Açık Kiraz - Light Cherry



NB 871
Koyu Kiraz - Dark Cherry



NB 856
İnce Altın Meşe - Golden Oak Fine Wood

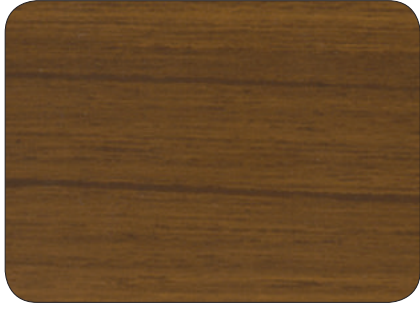

NB 876
Tik - Teak

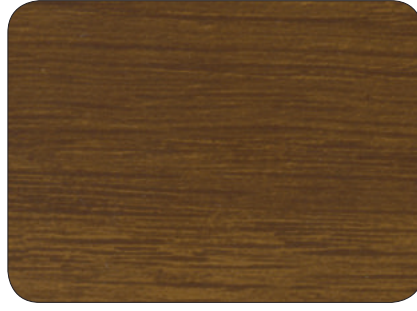

NB 875
Afrika Tiki - African Teak



NB 859
İnce Ceviz - Nussbaum Fine Wood



NB 858
Kalın Maun - Mahogany

RENKLER / COLORS

RENKLER COLORS



DİĞER RENKLER / OTHER COLORS

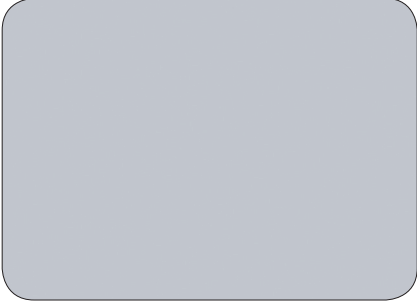

NB 092
Parlak Metalik Gümüş -
Shiny Metallic Silver

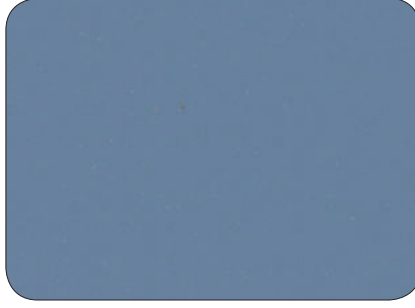

NB 860
Parlak Metalik Gümüş Mavi -
Light Blue Metallic Silver

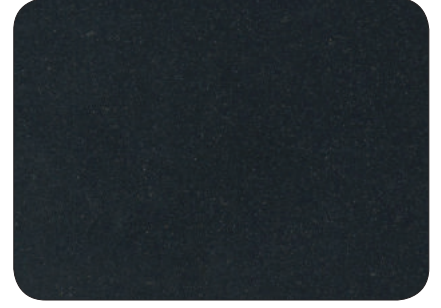

NB 861
Siyah Metalik - Black Metallic



NB 877
Satine Gümüş - Brush Silver



NB 878
Satine Bakır - Brush Copper

YÜZEY SEÇENEKLERİ / SURFACE OPTIONS

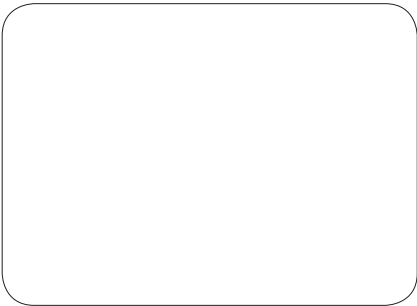

NB 905
Nano Beyaz - Nano White *

*Nano özelliği, sipariş miktarına göre tüm düz renkler için uygulanabilmektedir.

*Nano effect can be applied for all solid colors depending on the amount of the order.

GENEL ÖZELLİKLER / GENERAL FEATURES

İşlemler / Process

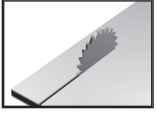

Kesme / Cutting

Kesme işlemi testere ya da oyma testere ile yapılabilmektedir. Oluk Açma: 90 derecelik bir köşe dönüşü için, 110 derecelik bir kertme bıçağıyla kertilmesi tavsiye edilmektedir. Kerterken dış kısımda 0.2~0.4mm 'lik çekirdek kısmın da kalmasına dikkat edilmelidir.

Cutting can be made through saw or fret saw. Opening grooves: For 90 degrees of corner return, it should be notched by a notching blade of 110 degrees as recommended. While notching, a nucleus part of 0.2 - 0.4mm is required to be left in the outer part.

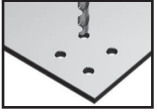

Delme / Boring

Bu işlem burgulu matkapla yapılır.

This process is to be made with twisted drill.



Kontur / Contour

Bu işlem oyma testere, kontur testeresi ve freze makinası ile yapılabilir.

This process is to be made by fret saw, contour saw and milling.

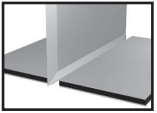

Bişme / Hewing

Bu işlem giyotin ile yapılabilir.

This process is to be made with guillotine.



Delme / Boring

Bu işlem delme makinası ile yapılabilir.

This process is to be made by boring machine.



Bükme / Bending

Bu işlem fren basınç aleti ve katlama tablası ile yapılabilir. 3mm ve 4mm için minimum bükülme yarıçapı tekli için 40mm, paralel için 50mm, 6mm için minimum bükülme yarıçapı tekli için 55mm, paralel için 80mm.

This process can be made by brake pressure device and folding table. For 3mm and 4mm, minimum bending radius is 40mm for single, 50mm for parallel; for 6mm, minimum bending radius is 55mm for single, 80mm for parallel.

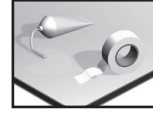

Yapıştırma / Sticking

Bu işlem metal yapıştırıcısı ile yapılabilir.

This process can be made by metal sticking.



Perçinleme / Riveting

Bu işlem perçin ile yapılabilir.

This process can be made by rivet.

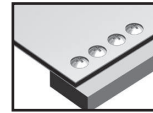

Vidalama / Screwing

Bu işlem metal vidalarla ile yapılabilir.

This process can be made by metal screws.



Kaynaklama / Welding

Bu işlem sıcak hava kaynağı ile yapılabilir.

This process can be made by hot air welding.

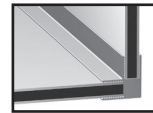

Kenetleme / Coupling

Bu işlem köşe birleştirici profiller ile yapılabilir.

This process can be made with corner assembling profiles.

ÜRÜN DETAYLARI / PRODUCT DETAILS

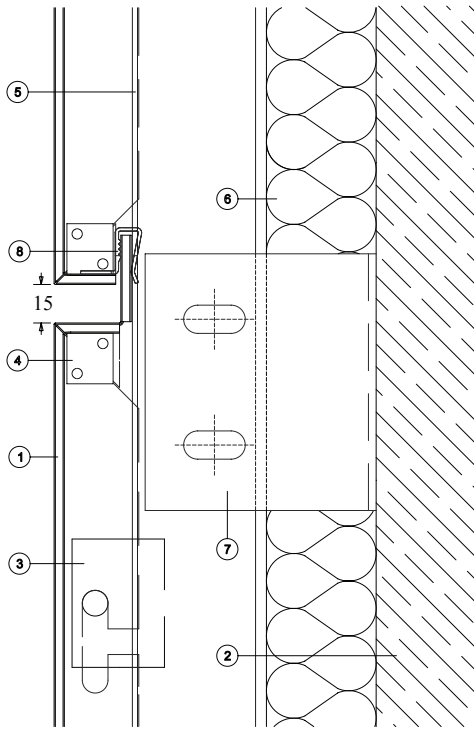

- ① NATURALBOND
- ② BETONARME / CONCRETE
- ③ ANAHTAR GEÇME BAĞLANTISI / COMPOSITE CONNECTING ANCHORAGE (08.01.04)
- ④ 20X20X1.2mm ALÜMİNYUM KÖŞEBENT (163) / 20X20X1.2 MM ALUMINIUM PROFILE
- ⑤ ALÜMİNYUM DÜŞEY TAŞIYICI PROFİL (10634) / ALUMINIUM MULLION PROFILE (10634)
- ⑥ TAŞ YÜNÜ / ISOLATION
- ⑦ ALÜMİNYUM ANKRAJ / ALUMINIUM ANCHORAGE (08.01.03)
- ⑧ ALÜMİNYUM BAĞLANTI PROFİLİ / ALUMINIUM CONNECTING PROFILE (6773)
- ⑨ EPDM FİTİL/ EPDM GASKET (01.07.10.50R)

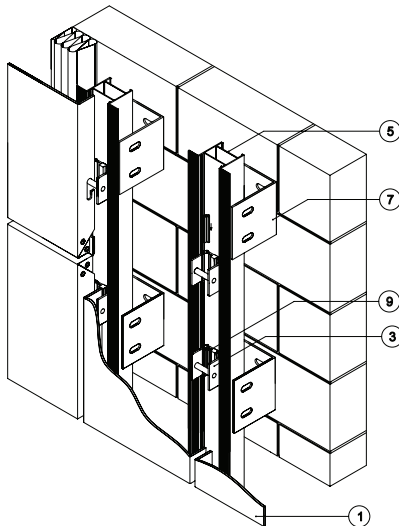
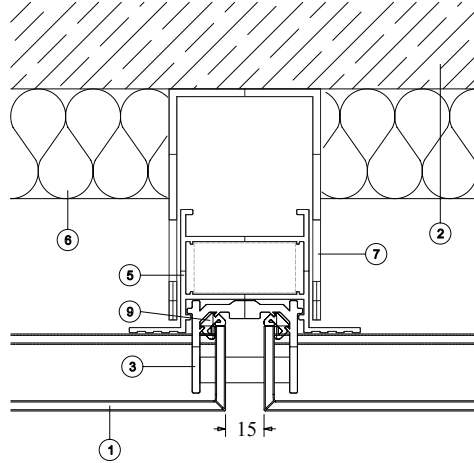

	ANAHTAR GEÇME BAĞLANTISI COMPOSITE CONNECTING ANCHORAGE (08.01.04)
	ALÜMİNYUM ANKRAJ ALUMINIUM ANCHORAGE (08.01.03)



ASAŞ Alüminyum Sanayi ve Ticaret A.Ş.

Genel Müdürlük / Headquarters

Rüzgarlı Bahçe Mah., Kumlu Sok., No: 2
Asaş İş Merkezi, 34810 Kavacık
Beykoz - İstanbul, Türkiye
T +90 216 680 07 80 **F** +90 216 680 07 81

**Alüminyum Profil ve Kompozit Panel Üretim Tesisleri /
Aluminium Profile and Composite Panel Production Facilities**

Küçücek İstiklal Mah., Kışla Alanı Cad.,
No: 2-2/1, 54400 Akyazı - Sakarya, Türkiye
T +90 264 462 47 92 **F** +90 264 462 47 96
asastr.com

